

Operating Instructions and Owner's Manual

LF160F, LF168F, LF168F-2, LF170

PLEASE READ THIS MANUAL CAREFULLY BEFORE OPERATING YOUR NEW
LIFAN POWER USA ENGINE

(Q) Indicates this Engine has a Keyway Horizontal Output Shaft

(P) or (T) or (W) Indicates this Engine has a Threaded Horizontal Output Shaft

(13111) Indicates this Engine has a Tapered Horizontal Output Shaft

(R) Indicates this Engine has a 2:1 Clutch Reducer

(H) Indicates this Engine has a 6:1 Gear Reducer

(-CA) Indicates this unit is CARB Certified for California

PLEASE READ THE FOLLOWING INSTRUCTIONS!

1. Unit Shipped with “NO OIL” in Engine or where applicable pumps and/or accessories. Check and fill with proper oil as outlined in the Owner’s Manual for the respective product.

2. For repair under Warranty or questions concerning Warranty, DO NOT return this product to the Store where purchased. Follow the procedures as outlined in the “WARRANTY POLICY” and “WARRANTY REGISTRATION” in the Owner’s Manual. For any questions visit www.lifanpowerusa.com or call 1-866-471-7464.

3. Read the “Owner’s Manual” prior to operating any equipment and familiarize yourself with the proper and safe operation of the equipment. If you have any questions visit www.lifanpowerusa.com or call 1-866-471-7464.

This Owner’s Manual is for the Following Models:			
			
LF160F	LF168F	LF168F-2	LF170

(Q) Indicates this Engine has a Keyway Horizontal Output Shaft
(P) or)T) or (W) Indicates this Engine has a Threaded Horizontal Output Shaft
(13111) Indicates this Engine has a Tapered Horizontal Output Shaft
(R) Indicates this Engine has a 2:1 Clutch Reducer
(H) Indicates this Engine has a 6:1 Gear Reducer
(-CA) Indicates this unit is CARB Certified for California

Table of Contents

Preface	4
Product Specifications	5
Safety Instructions	6
Controls and Features	10
PRE-OPERATING INSTRUCTIONS	12
Assembly	12
Engine Setup	13
Operation of Engine	16
Storing the Unit	19
Maintenance	20
Troubleshooting	24
Engine Safety	25
Limited Warranty Policy	26

Preface

Thank you for choosing LIFAN Power USA for your Engine needs. LIFAN Power USA prides itself on providing quality engines at affordable pricing.

All LIFAN Power USA products are manufactured utilizing the latest technology. Built with quality components, your new LIFAN Power USA engine will give you years of dependable service.

This Owner's Manual will provide you with all of your needed information for your new LIFAN Power USA engine, including Safe Operation and Maintenance of your unit. Please read this Owner's Manual completely and carefully prior to operation. Keep this Owner's Manual for assistance in the future, such as proper maintenance schedules and tips to prolong the life and effective use of your unit. If you require assistance, please visit our website (www.lifanpowerusa.com) or call toll free 866-471-7464.

This Owner's Manual contains information with respect to the newest products at the time of publication. Due to revision and modifications, the information noted in the Owner's Manual might vary from the actual status. This Owner's Manual is subject to change without notice. The copyright of this Owner's Manual belongs to EquipSource, LLC. Any group or individual is forbidden to reprint or copy any of this Owner's Manual without the written consent of EquipSource, LLC.

FOR ALL WARRANTY AND SERVICE RELATED ISSUES/QUESTIONS DO NOT RETURN YOUR UNIT TO THE STORE OR DEALER WHERE THE ITEM WAS PURCHASED. FOR SERVICE VISIT LIFAN POWER USA'S WEBSITE (WWW.LIFANPOWERUSA.COM) OR CALL 1-866-471-7464. WE WILL BE HAPPY TO HANDLE YOUR WARRANTY ISSUE OR DIRECT YOU TO THE NEAREST "AUTHORIZED SERVICE CENTER."



LIFAN Power USA



PRODUCT SPECIFICATIONS

PRO SERIES ENGINES

Model	LF160F	LF168F	LF168F-2	LF170
Manufacturer	LIFAN	LIFAN	LIFAN	LIFAN
Engine Type	4-Stroke OHV Single Cylinder			
Maximum Horsepower (MHP)	4MHP	5.5MHP	6.5MHP	7MHP
Displacement	118cc	163cc	196cc	212cc
Bore X Stroke	60mm X 42mm	68mm X 45mm	68mm X 54mm	70mm X 55mm
Compression Ratio	8.5:1	8.5:1	8.5:1	8.5:1
Engine Speed	3600 rpm	3600 rpm	3600 rpm	3600 rpm
Starting System (D Models Only)¹	Recoil (Recoil/Electric)	Recoil (Recoil/Electric)	Recoil (Recoil/Electric)	Recoil (Recoil/Electric)
Fuel Tank Capacity	0.66 Gallons	0.95 Gallons	0.95 Gallons	0.95 Gallons
Fuel Type	87 Octane Gasoline			
Engine Oil Type & Amount	SAE 10w30w 20oz			
Low Oil Shutoff Protection	Yes	Yes	Yes	Yes
CARB Certified	(-CA) Models Only			

Horizontal Output Shaft Options

Keyway (Q Models) Diameter	0.75 in	0.75 in	0.75 in	Special Order Only
Threaded (P Models) Diameter	Special Order Only	Special Order Only	Special Order Only	Special Order Only
Threaded (T Models) Diameter	Special Order Only	Special Order Only	5/8 in (18x1.25 Thread)	Special Order Only
Threaded (W Models) Diameter	Special Order Only	Special Order Only	20 mm	Special Order Only
Tapered (13111 Models) Diameter	Special Order Only	Special Order Only	Generator Engine	Generator Engine
2:1 Clutch Reduction (R Model) Diameter	Special Order Only	Special Order Only	20mm	Special Order Only
6:1 Gear Reduction (H Model) Diameter	0.75 in	Special Order Only	0.75 in	Special Order Only

Horizontal Keyway Output Shaft Dimensions

Length	16 in	16 in	16 in	16 in
Width	15 in	15 in	15 in	15 in
Height	14 in	16 in	16 in	16 in
Dry Weight	32.5 lbs	38 lbs	38 lbs	38 lbs

Legend

Dimensions given are for "Q" Models only. Other Engine options will cause dimensions to vary.

¹ = Only "D" Models have Recoil & Electric Start

LF168F-2W = 6.5MHP 20mm Horizontal Threaded Output Shaft

LF168F-2Q = 6.5MHP Horizontal Keyway Output Shaft

LF168F-2-13111 = 6.5MHP Horizontal Tapered Output Shaft

LF177FP = 9MHP Horizontal Threaded Output Shaft

LF168F-2R = 6.5MHP with 2:1 Clutch Reduction

LF168F-2T = 6.5MHP 5/8" Horizontal Threaded Output Shaft

LF168F-2H = 6.5MHP with 6:1 Gear Reduction

2205 Industrial Park Road
Van Buren, AR 72956
866 741-7464



For Additional LIFAN Product Information,
Scan the QR Code to the Left, Or Visit
www.lifanpowerusa.com

Safety Instructions









This is the safety alert symbol. It is used to alert you to potential personal injury hazards. Obey all safety messages that follow this symbol to avoid possible injury or death.

For your safety read this manual carefully. Become familiar with the proper operation, care, and maintenance of your LIFAN Power USA generator.

The safety and alert symbol () is used with a signal word (**CAUTION**, **DANGER**, **WARNING**), a pictorial and/or safety message to alert you to hazards. **CAUTION** indicates a hazard that, if not avoided, could result in minor or moderate injury. **DANGER** indicates a hazard that, if not avoided, could result in death or serious injury. **WARNING** indicates a hazard that, if not avoided, could result in death or serious injury.

Hazard Symbols and Meanings

		
Explosion Shock	Fire	Electrical
		
Toxic Fumes	Hot surface or gas	Kickback



WARNING!

Running engine emits carbon monoxide: an odorless, colorless, poison gas.
Breathing carbon monoxide can cause nausea or death!

ONLY operate engine outdoors.

Exhaust gas must be prevented from entering confined areas.

Direct exhaust gas away from windows, doors, ventilation and other openings.

Do not operate engine inside or under any buildings.

Operating this engine inside the compartment of a recreational vehicle will likely result in death!



WARNING!

The engine exhaust contains chemicals known to the state of California to cause birth defects, reproductive harm, and cancer.







Do not use this engine within the generator compartment of a recreational vehicle!

This engine does not meet U.S. Coast Guard Regulation 33CFR-183 and should not be used on marine applications.

Use of this engine on marine applications could result in injury or death.

Safety Instructions (continued)

	WARNING!
	<p>Rapid recoil of starter cord (kickback) may pull hand and arm forward toward engine at a rapid rate. Broken bones, bruises, sprains, and fractures may result.</p>
<ul style="list-style-type: none"> • When starting engine, pull cord slowly until tension is felt, and then pull rapidly to avoid kickback. • Never start or stop engine with electrical devices plugged in and turned on. Doing so is hazardous and will damage generator. 	

	WARNING!
	Fuel and its vapors are extremely flammable and explosive.
	Fire or explosion can cause severe burns or death.
<p>WHEN ADDING OR DRAINING FUEL</p> <ul style="list-style-type: none"> • Turn engine off and let it cool for at least three minutes before removing fuel cap. Loosen cap slowly in order to relieve pressure in the fuel tank. • Fill or drain fuel tank outdoors. Do not excessively inhale fuel vapors. • Keep away from open flames or sparks and other sources of ignition. • Do NOT smoke while filling fuel tank. • Do NOT overfill tank. Allow space for fuel expansion. <p>WHEN TRANSPORTING OR REPAIRING EQUIPMENT</p> <ul style="list-style-type: none"> • Transport engine with the fuel valve in the off position. • Repair engine with the fuel tank empty or the fuel valve in the off position. • Disconnect spark plug wire before transport or service. <p>WHEN STORING FUEL OR EQUIPMENT CONTAINING FUEL</p> <ul style="list-style-type: none"> • Store away from furnaces, stoves, water heaters, clothes dryers or other appliances that have pilot light or other ignition source because they can ignite fuel vapors. <p>WHEN STARTING EQUIPMENT</p> <ul style="list-style-type: none"> • Ensure spark plug, muffler, air cleaner, and fuel cap are in place. • Do NOT crank engine with spark plug removed. • If fuels spills, wait until it evaporates before starting engine. <p>WHEN OPERATING EQUIPMENT</p> <ul style="list-style-type: none"> • Do not choke carburetor to stop engine. • Do not tip engine or equipment at an angle, which causes fuel to spill. • This engine is not for use in marine applications. 	

Safety Instructions (continued)



CAUTION!

Excessively high operating speeds (engine revolutions) increase the risk of injury and damage to the engine. Excessively low speeds impose a heavy load and will damage engine.

- Do NOT adjust engine speed governor.
- Modifying engine in any way may be dangerous and will void warranty.



WARNING!



**While engine is running temperature may exceed 150°F (65°C).
Server burns may occur.**



Exhaust heat/gasses can ignite combustibles, structures or damage fuel tank causing a fire.

- Do NOT touch hot surfaces and do avoid exhaust gasses.
- Allow engine to cool before touching.
- Keep at least 6 ft. (183cm) clearance on all sides of engine including overhead clear.
- Reflective exhaust heat may damage fuel tank causing fire.
- Code of Federal Regulation(CFR) Title 36 Parks, Forests, and Public Property require equipment powered by an internal combustion engine to have a spark arrester, maintained in working order, complying to USDA Forest service standard 5100-1c or later revision. In the state of California a spark arrester is required under section 4442 of the California Public resources code.



WARNING!



Unintentional sparking can result in fire or electrical shock.



WHEN TESTING FOR ENGINE SPARK

- Do NOT check for spark with the spark plug removed.
- Use approved spark plug tester.

WHEN REPAIRING OR ADJUSTING ENGINE

- Disconnect the spark plug wire from the spark plug and place the wire where it cannot contact spark plug.

Safety Instructions (continued)

CAUTION!

Improper use and care of this engine will cause damage and shorten its lifespan. Failure to follow these actions will void all warranties.

- Use engine only for appropriate and designated purposes.
- The dealer or customer helpline (1-866-471-7464) can instruct you on intended uses.
- Engine must be placed on a level surface.
- Do NOT expose Engine to extreme conditions. Excessive dust, moisture, and corrosive vapors will damage unit.
- Cooling slots must be kept clear of debris.
- Do not connect improperly operating devices to engine.
- Shut off engine and take to a qualified service center if the engine fails to operate properly.

Controls and Features

Read this Owner's Manual Completely and Carefully before Operating Engine.

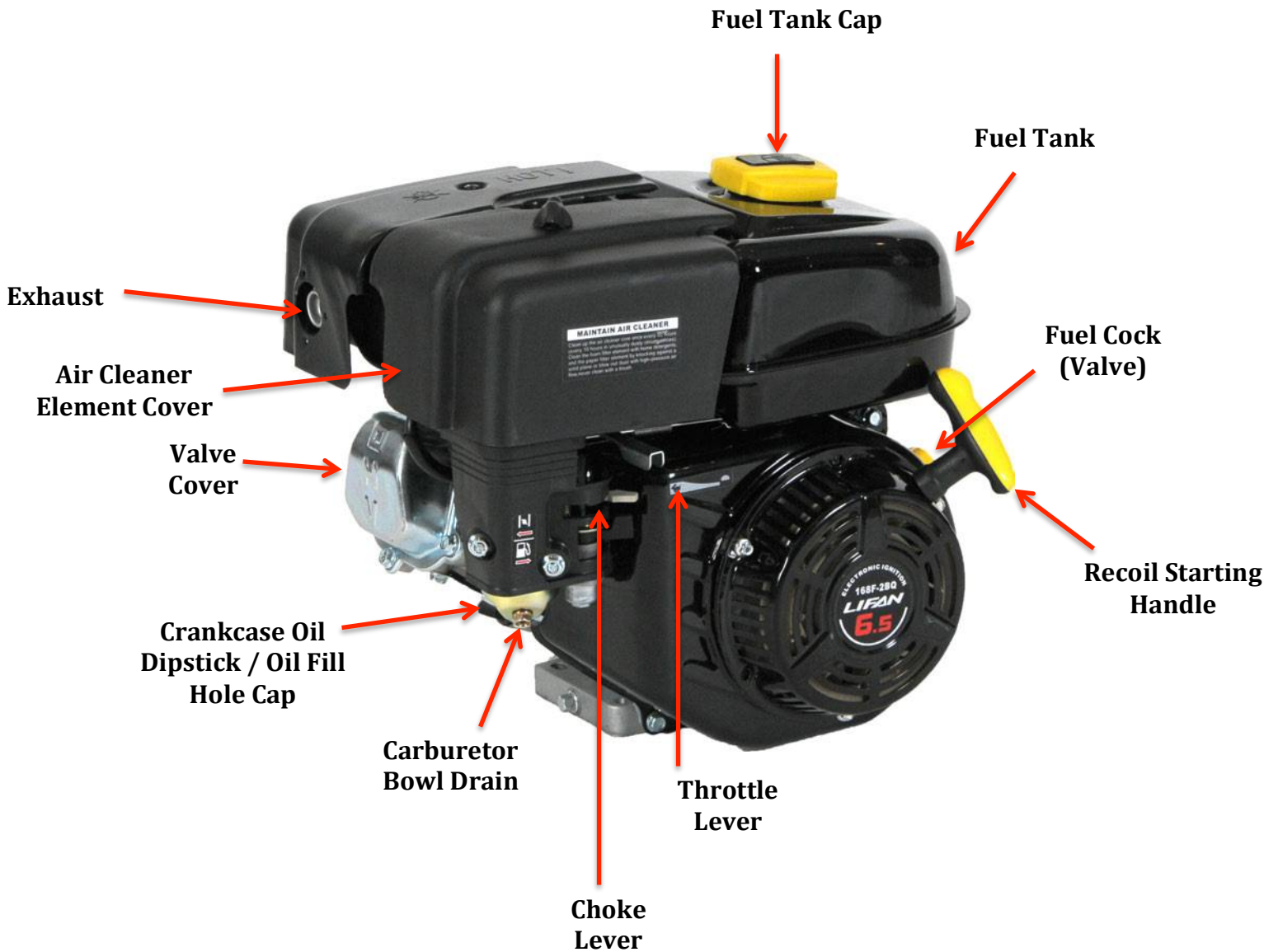

Controls and Features (continued)

Legend

1. **Fuel Tank Cap** – Vented Fuel Cap Must be Properly Installed at all times during Operation.
2. **Fuel Tank** – Contains Gasoline for Operation.
3. **Fuel Cock (Valve)** – Turn to “OFF” to Terminate Fuel Delivery to Engine
4. **Recoil Starting Handle** – Pull Handle to Rotate Engine for Starting.
5. **Throttle Lever** – Push toward “Rabbit” for “FAST” operation; Push toward “Turtle” for “SLOW” operation.
6. **Choke Lever** –
Before starting cold engine, push the Choke Lever to the “LEFT” to activate choke. After allowing engine to operate for a few seconds, push Choke Lever to the “RIGHT” designated by the gas pump symbol.
7. **Carburetor Bowl Drain** – Refer to Fuel System Maintenance in the Maintenance Section of this Owner’s Manual.
8. **Crankcase Oil Dipstick/Oil Fill Hole Cap** – Check/Fill Engine Oil.
9. **Valve Cover** – Cover for Overhead Valves designed to be removed periodically for valve adjustments.
10. **Air Cleaner Element Case** – Check Maintenance Schedule for Service Intervals.
11. **Exhaust** – Avoid contact; Only Ventilate in open, outdoor areas.

Pre-Operating Instructions: Assembly

Your LIFAN Power USA engine is packaged without fuel and oil.

For further assistance, please visit our website (www.lifanpowerusa.com) or call 1-866-471-7464 between the hours of 9am-5pm Monday-Friday.

BOX CONTENT:

- Engine
- Owner's Manual and Warranty Card

UNPACKING THE ENGINE:

1. Set the Carton on a Flat, Rigid Surface.
2. Open Top of Box.
3. Remove All Contents from Carton EXCEPT Engine.
4. Open Box Completely by Cutting Each Corner from Top to Bottom.
5. Carefully Lift Engine Out of the Box and Plastic and Set in Flat, Rigid Surface.

Pre-Operating Instructions: Engine Setup

CAUTION: Any attempt to start the engine before it has been properly serviced may result in engine failure and void warranty.

ADD ENGINE OIL: Refer to the diagrams below.

1. Ensure engine is on level surface.
2. Clean area around Oil Hole Dipstick/Plug & Unscrew Oil Hole Dipstick/Plug.
3. Fill with appropriate type and amount. Refer to Chart below for recommended oil type based on Environmental temperature.

NOTE: Refer to "Product Specifications" section for universal recommended oil type and oil amount.

4. Replace Oil Hole Dipstick/Plug and tighten securely.

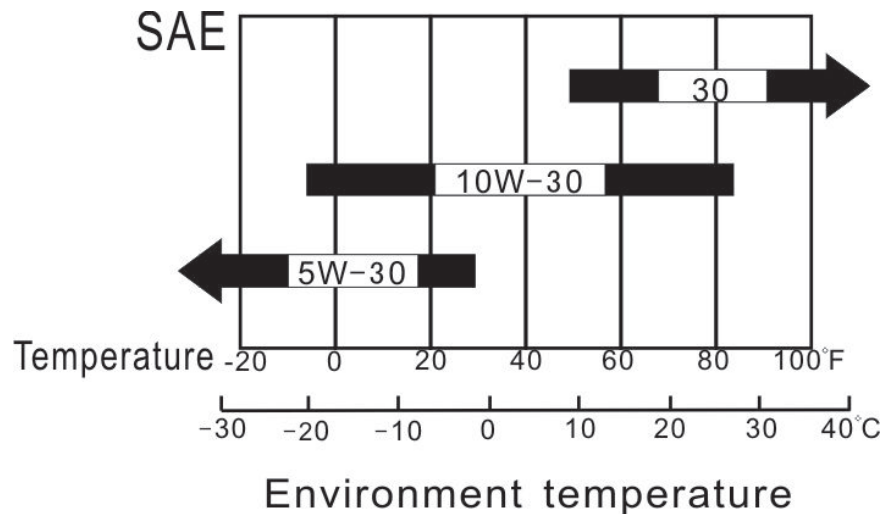

Pre-Operating Instructions: Engine Setup (continued)



WARNING!



Fuel and its vapors are extremely flammable and explosive.



Fire or explosion can cause severe burns or death.

WHEN ADDING FUEL

- Turn engine off and let it cool for a minimum of three minutes before removing fuel cap. Turn and remove cap slowly in order to relieve residual tank pressure.
- Always fill the fuel tank with the unit outdoors.
- DO NOT overfill tank. Allow room for fuel expansion.
- Keep fuel away from sparks, open flames, heat, pilot lights, and other ignition sources.

ADD FUEL: Refer to Controls and Features section for diagrams.

1. Clean area around fuel cap, then remove fuel cap.
2. Pour fresh, clean regular automotive grade unleaded fuel with a minimum octane rating of 85 into fuel tank. Do NOT mix fuel with oil. Fuel must have ethanol blend of 15% or less. Pay close attention to the storage requirements of these fuels. Do NOT overfill fuel tank.
3. Install the fuel cap. Rotate the fuel cap clockwise until it is in its locked position. Wipe away any spilled fuel.

CAUTION: Alcohol-blended fuels (gasohol, ethanol, or methanol) will attract moisture, which leads to separation and formation of acids during storage. Acidic gas can damage the fuel system of an engine while in storage. To avoid engine problems, the fuel system should be treated with a fuel stabilizer or drained if the generator will not be started for thirty (30) days. If using a fuel stabilizer, follow the manufacture's recommended instructions for use. Always use stabilizer with a full tank of gasoline. Always drain old fuel and use fresh fuel before next use. If you do not use a fuel stabilizer, the fuel system must be drained and cleaned. Drain the fuel tank and start the engine, allowing it to run until all fuel lines and carburetor are drained of fuel. Before restarting the carburetor. Float bowl must be removed and cleaned of any debris.

NEVER use chemical solvents or cleaners in the fuel tank for damage may occur.

Pre-Operating Instructions: Engine Setup

(continued)



CHECK AIR CLEANER ELEMENT:

Refer to “Air Cleaner Maintenance” in the Maintenance section of this Owner’s Manual to ensure Air Cleaner Element is in operable condition.

Operation of Engine

HOW TO USE YOUR ENGINE

ENGINE LOCATION:

	WARNING!
	Running engine gives off carbon monoxide gas. It is odorless, colorless, and highly toxic. Breathing carbon monoxide gas can lead to fainting, nausea or may result in death.
<ul style="list-style-type: none">• Only operate engine outdoors.• Prevent exhaust gas from entering, through windows doors or ventilation intakes, any confined areas.• DO NOT operate engine inside any enclosed or roofed areas. This includes the generator compartment of any recreational vehicle (RV).	

STARTING THE ENGINE: Refer to the Controls and Features section.

1. Make sure the engine is in a level position.
2. Open the fuel cock by turning the fuel cock to the “ON” position.
3. For cold engine starts only: Push the Choke Lever to the “CHOKE” position.

PULL START (RECOIL) ONLY MODELS:

4. Grasp starter handle and pull slowly until resistance is felt. Then pull the cord rapidly with a full arm stroke. Allow the rope to return slowly. Do NOT allow the rope to snap back against housing.
5. Once the engine runs for 3-5 seconds, push the Choke Lever to the “RUN” position, designated by the gas pump icon.

Operation of Engine

HOW TO USE YOUR ENGINE

(continued)

ELECTRIC/PULL (RECOIL) START MODELS:

5. Using provided key, turn the key switch to the “ON” position. Rotate the key one more position to the “START” position in order to engage the starting motor. Hold key switch in the “START” position until engine starts for NO MORE than 10 engine rotations. If the engine does NOT start repeat procedures beginning with Step One (1).
6. Once the engine runs for 3-5 seconds, push the Choke Lever to the “RUN” position, designated by the gas pump icon.

NOTE (all models): If engine does not start within three pulls, check the crankcase oil level. The engines “Low Oil Alarm System” may be activated and preventing the engine from starting.

LOW OIL ALARM SYSTEM:

This model is equipped with a Low Oil Alert System designed to avoid engine damage from insufficient oil in the crankcase. The Low Oil Alarm System will stop the engine automatically before the oil level in the crankcase drops below safe operating levels.

Operation of Engine

HOW TO USE YOUR ENGINE

(continued)

STOPPING THE ENGINE: Refer to Controls and Features section for diagram.

EMERGENCY SHUTDOWN

1. Turn the Fuel Valve to “OFF” position

NORMAL SHUTDOWN

1. In order to stabilize internal equipment temperatures, allow the engine to run for 3-5 minutes under no load.
2. If the engine will not be in use for more than 7 days, turn the fuel valve to the “OFF” position and allow the unit to run until the fuel in the carburetor is used and the engine shuts itself off.
3. Turn the ignition switch to the “OFF” position.
4. Allow unit to cool to ambient temperature before storage or transportation.
5. Always transport the unit with the fuel valve in the “OFF” position. Failure to do so will result in damage to the engine.

USAGE IN HIGH ALTITUDE REGIONS:

In regions with high altitude, the standard carburetor produces overly dense combinations of fuel and air, which result in decreased engine performance and increased fuel consumption. To maintain high engine performance at high altitudes, install a high altitude carburetor main spray nozzle and re-adjust the adjusting screw for idle speed. For usage in regions with an altitude of over 4,527ft (1380m), contact your dealer to replace the standard carburetor and make needed adjustments in advance. Even with a proper high altitude carburetor spray nozzle installed in the engine, the power output of the engine will drop about 3.5% with every 1000ft (305m) increase in altitude. If the standard carburetor jets are not replaced and adjusted for usage in high altitude, the increased altitude effect will be even more severe.

NOTE: Usage of the water pump in regions with lower altitude than the high altitude carburetor spray nozzle is applicable, may result in decrease of engine performance. The engine may become overheated and over-lean combination of fuel and air produced, may cause severe damage to the engine.

Storing the Unit

STORAGE: Refer to Controls and Features section or diagram and definitions.

Before long term storage of your power equipment product, typically 30 days or more, perform the following:

1. Set the fuel cock (valve) to the “OFF” position.
2. Let the unit continue to run until it stops itself, burning all of the fuel in the fuel system.
3. Turn the ignition switch to the “OFF” position.
4. Drain the engine oil in accordance with the “Oil Change Procedures” in this Owner’s Manual’s Maintenance section. Do NOT re-fill with oil until ready to use again.
5. Remove the Spark Plug in accordance with the “Spark Plug Maintenance” in the Owner’s Manual’s Maintenance section. Spray a lubricant, such as WD40®, into the Spark Plug hole to lubricate the top of the piston and walls of the cylinder. Replace the Spark Plug.
6. Pull starter rope until resistance is felt. This will place the valves in the closed position.
7. Add the recommended amount of fuel stabilizer, in accordance with the amount recommended by the manufacturer of the fuel stabilizer, to the unused gasoline left in the fuel tank.
8. Place the unit in a clean, dry, and secure location.
9. Cover with canvas/vinyl tarpaulin. Do NOT operate unit with cover installed.

Maintenance

MAINTENANCE SCHEDULE	
PROCEDURE	TIME
Engine Oil Check	Each Use
Replace Engine Oil	After Each 40 Hours of Use (For Initial Break in – After First (1 st) 10 Hours of Use
Air Cleaner Filter Check	Each Use
Air Cleaner Filter Replacement	When Needed or After Every 100 Hours of Use
Air Cleaner Wash	When Needed
Spark Plug	
Valve Clearance	Check & Re-adjust annually or after 300 Hours of Use
Fuel Tank	Replace Every 3 Years Based on Condition

NOTE: Refer to Following Procedures for Proper Method to Perform Maintenance

OIL CHANGE PROCEDURES: Refer to Controls and Feature section for diagram.

Periodic Maintenance of your engine oil should be performed after each 40 hours of use of you Power Equipment Product. Check your engine oil level prior to each use.

1. Start your engine and let it warm up to get the oil warm and thinner. Turn the engine On/OFF switch to the “OFF” position. Turn Fuel Valve to the “OFF” position.
2. Remove the oil cap/dipstick by turning counter clockwise. Remove the oil drain plug located below the oil cap/dipstick utilizing the appropriate tools.
USE CAUTION: THE OIL MAY BE HOT.
3. Drain the engine oil into an approved receptacle and discard in accordance with all Federal and State Regulations. Never dump the used engine oil on the ground or into drains, only discard in an approved manner. Check with your local authorities to determine the regulations in your area.
WARNING! AVOID SPLASHING OF HOT OIL; IT CAN BURN YOU AND CAUSE SEVERE INJURY.
4. After oil is completely drained, replace oil drain plug and tighten with appropriate tools. Replace oil with the proper oil for your product. Refer to the Pre-Operating Instruction: Generator Setup section for exact fill requirements.

Maintenance (continued)

OIL CHANGE PROCEDURES (continued):

Always use your dipstick to check the oil level and only fill to the full mark on the dipstick. Never overfill the engine as this can cause damage to the unit and void warranty.

5. Replace the dipstick/oil cap on the engine.
6. Shake generator to ensure the float in the Oil Alert System is free.

PROPER MAINTENANCE OF THE UNIT WILL INCREASE THE LIFE OF YOUR PRODUCT. THE OIL MUST BE CHANGED ON A REGULAR BASIS FOR PROPER OPERATION, AND RELIABILITY AND TO ALSO MAINTAIN THE WARRANTY ON THIS PRODUCT.

AIR CLEANER MAINTENANCE:

1. Remove the clip (item 9 in “Air Cleaner A” below) or the wing nut (item 7 in “Air Cleaner B” below) to remove and check the air filter element.
2. For Sponge Type Air Filters, wash with soap and water when contaminated. Squeeze excess liquid from air filter element, and allow the air filter element to dry.
For Paper Type Air Filters, replace with the correct Air Filter for your unit. They are available at your dealer or from LIFAN Power USA. Order your filter by calling toll free 866-471-7464.
3. Re-Install the air filter element into the air filter housing.

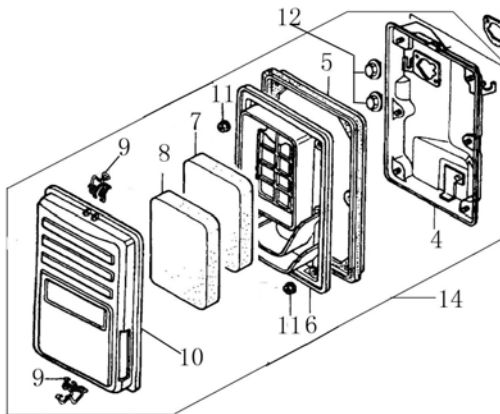

Air Cleaner A

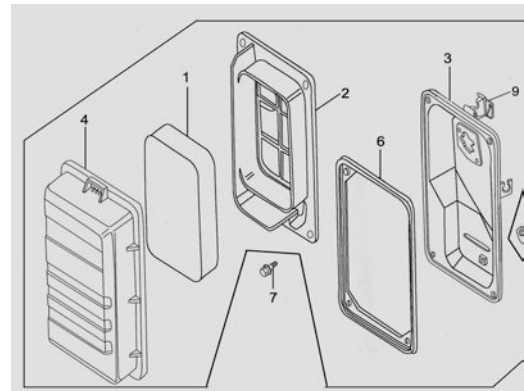

Air Cleaner

Maintenance (continued)

SPARK PLUG MAINTENANCE:

1. Remove Spark Plug Cap (refer to "Spark Plug Cap Removal" figure below.)
2. Remove Spark Plug with socket and handle supplied with your unit (refer to "Spark Plug Removal" figure below.)
3. Clean any carbon build-up around the Spark Plug.
4. Check the Spark Plug Gap and adjust if necessary. 0.30-inch gap.
5. Lubricate the threads of the Spark Plug with anti-seize compound or engine oil.
6. Re-install the Spark Plug and Spark Plug Cap.

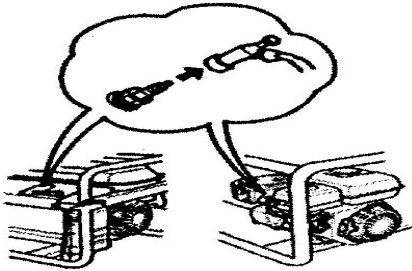

Spark Plug Cap Removal

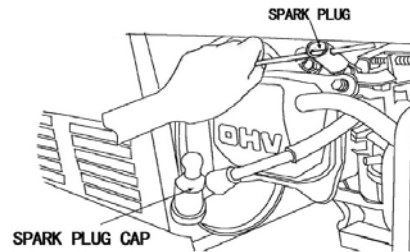

Spark Plug Removal

FUEL SYSTEM MAINTENANCE:

NOTE: Periodically you can get sediment or trash in your Carburetor Bowl. Use the following procedures to clean:

1. Turn the fuel cock (valve) to the "OFF" Position.
2. Remove the carburetor bowl by removing the mounting bolt located at the bottom of the bowl.
3. Dump out the old fuel and sediment into an approved container and clean carburetor bowl thoroughly.
4. Fit a new rubber washer into place and re-attach fuel bowl to the carburetor.

NOTE: Removal of the drain screw at the bottom of the bowl can drain the fuel to remove smaller debris that has collected in the bowl.

5. After bowl is securely back in place, turn the fuel cock (valve) to the "ON" position for use.
6. Units equipped with a pre-filter for fuel will have a filter housed just below the fuel cock. Remove the fuel filter element (refer to "Fuel Filter Element Removal")

Maintenance (continued)

FUEL SYSTEM MAINTENANCE (continued):

diagram below) and either clean or replace the fuel filter element. Re-assemble the fuel filter element (refer to “Fuel Filter Element Assembly” diagram below.)



Fuel Filter Element Removal



Fuel Filter Element Assembly

Troubleshooting

IF THE ENGINE WILL NOT START:

1. Check to ensure switches are in the “ON” position. (Both unit and engine)
2. Check engine oil level. Your unit possesses a Low Oil Alarm System that will not allow your engine to start if the oil is below safe operating levels. This feature is installed to increase the life of your engine and prevent engine damage. If oil level is low, fill to the full mark on dipstick. Refer to the Product Specifications for exact oil type and amounts.
3. Check the fuel level to insure adequate fuel. Add fuel if necessary.
4. Remove and inspect the spark plug for cleanliness and proper electrode gap. If needed, clean or replace the spark plug. Refer to Spark Plug Maintenance in the Maintenance section of the Owner’s Manual for proper procedure.
5. If your unit will still NOT start after performing the above checks, call our customer hotline at LIFAN Power USA Toll Free 1-866-471-7464 or take your unit to an authorized Service Center.

NOTE: Periodically on the initial start-up or after the unit has been stored for a long period of time, the float for the “Low Oil Alarm System” will stick to the bottom of your oil pan. Locate the two (2) wires to the Low Oil Sensor Diode (refer to figure on the right) located on the side of the engine block. Unplug these wires and, **only after ensuring the engine is full of oil**, start the engine and allow to run until warm (normally 20 minutes, as this will heat the oil and release the float on the Low Oil Alert System). Then re-plug the wires to the terminals on the Low Oil Alarm Sending Unit.



Engine Safety

1. Never operate gasoline engine powered products in any enclosed spaces, as they product deadly Carbon Monoxide Poisonous Gases.
2. Do NOT operate your power equipment in inclement weather such as rain, snow, and/or sleet.
3. Do NOT operate your power equipment within six (6) feet of any flammable materials.
4. When refueling the power equipment never smoke or refuel near any flame or ignition devices. Never refuel while the unit is running. If during the refueling process some fuel is spilled, always completely clean the fuel and allow sufficient drying time prior to re-starting the unit. Gasoline vapors ignite easily and are very dangerous.
5. Do NOT lengthen the exhaust pipe or vent it with any extension.
6. NEVER ALLOW CHILDREN OR ANIMALS TO BE NEAR THIS EQUIPMENT DURING OPERATION. ONLY QUALIFIED PERSONS SHOULD OPERATE THIS EQUIPMENT. FOLLOW ALL GUIDELINES CONTAINED IN THIS OWNER'S MANUAL FOR THE SAFE OPERATION OF THIS EQUIPMENT.

25

LIFAN Power USA
2205 Industrial Park Road
Van Buren, AR 72956
866-471-7464
www.lifanpowerusa.com



Limited Warranty Policy



This warranty is limited to the following LIFAN Power and Storm Series products that are distributed by the EquipSource LLC, dba LIFAN Power USA, located at 2205 Industrial Park Road, Van Buren, AR 72956. Effective 04/25/2010

LENGTH OF WARRANTY				
Products Covered	Residential Use ²			Commercial/Rental ³
	Year 1	Year 2	Year 3	Warranty NOT to exceed 300 hours or terms listed below:
Walk Behind Mowers	Full Unit: Parts & Labor	Full Unit: Parts Only	Engine: Parts Only	Full Unit: 3 Months Parts & Labor
Water Pumps	Full Unit: Parts & Labor	Full Unit: Parts Only	Engine: Parts Only	Full Unit: 12 Months Parts & Labor
Generators/Inverter Generators	Full Unit: Parts & Labor	Full Unit: Parts Only	Engine: Parts Only	Full Unit: 12 Months Parts & Labor
Pressure Washer Engines	Full Unit: Parts & Labor	Full Unit: Parts Only	Engine: Parts Only	Full Unit: 12 Months Parts & Labor
Pressure Washer Pumps ¹	Full Unit: Parts & Labor	N/A	N/A	Full Unit: 12 Months Parts & Labor
Gasoline Engines	Full Unit: Parts & Labor	Full Unit: Parts Only	Engine: Parts Only	Full Unit: 12 Months Parts & Labor
Gasoline Powered Welders	Full Unit: Parts & Labor	Full Unit: Parts Only	Engine: Parts Only	Full Unit: 6 Months Parts & Labor

Pressure Washer Pumps¹ - All LIFAN Pressure Pro™ and Storm Series Pressure Storm™ pressure washers are equipped with Annovi Reverbi  high pressure water pumps, which are warranted by the manufacturer's One (1) Year Limited Warranty. Visit www.lifanpowerusa.com for details.

Residential Use² - Residential Use is defined as items that are for personal use.

Commercial/Rental³ - Commercial or Rental use is defined as any usage for income producing or other business related uses.

In order to qualify for the limited warranty, the product(s) must be purchased in North America from an authorized EquipSource, LLC dealer, or a dealer authorized by EquipSource, LLC to sell LIFAN products. This warranty is non-transferable and applies only to the original purchaser. The supplied "Warranty Registration Card" must be completed and on file with EquipSource, LLC (at the supplied address), at the time that any warranty claim is made. The "Warranty Registration Card" must be submitted with a receipt of purchase, which clearly states the date of purchase.

During the warranty period (stated above), EquipSource, LLC will repair or replace, at its option, any part that is proven to be defective in material or workmanship under normal usage. Repairs and/or replacement will be made without charge for parts or labor. All parts found to be defective must be returned to EquipSource, LLC. Upon reception of the parts, a judgement as to the validity of the warranty claim will be determined. All parts replaced under warranty will be considered part of the original product and any warranty on those parts will coincide with the original warranty.

To obtain warranty service, you must take the product, at your expense, to an authorized LIFAN Power Products or Storm Series Power Products service center. If you are unable to locate warranty service or are dissatisfied with the warranty service that you receive, contact EquipSource, LLC at 866-471-7464. At EquipSource's discretion, EquipSource, LLC may elect to replace a defective unit. In this case, the end user is responsible for all shipping and handling charges associated with the exchange.

This warranty is not valid for products or parts affected or damaged by accident, collision, normal wear, fuel contamination, abuse, neglect, misuse, alteration, unsuitable use, and/or unauthorized parts replacement. Mower decks and blades are specifically not warranted for impact or abrasive damage. Warranty becomes void if the customer fails to install, maintain, and/or operate this product in accordance with the instructions and recommended actions of LIFAN set forth in the owner's manual. EquipSource, LLC disclaims any responsibility for time loss or loss of usage of the product, transportation, commercial loss, or any other incidental or consequential damage. Prior to any warranty service an approval code must be issued to the service center in order for the warranty claim to be valid. Any implied warranties are limited to the duration of this written limited warranty. This warranty gives you specific legal rights, and you may also have other rights, which may vary from state to state.

Exclusions to Warranty:

- Failure to perform "Periodic Maintenance" as required and specified in the supplied "Owner's Manual."
- Improper repair of product or replacement of parts with non-OEM (Original Equipment Manufacturer) parts.
- Operation in uses and methods other than those outlined in the "Owner's Manual."
- Service and/or repairs performed by anyone other than an "Authorized LIFAN or Storm Series Products Service Center."

More Information Available on our website: www.lifanpowerusa.com EquipSource, LLC

2010 Revised 04/25/2010



**Please Read this Owner's Manual Carefully Before Operating
Your New LIFAN Power USA Engine.**

**This Owner's Manual includes the operation and maintenance of
the LF160F, LF168F, LF168F-2, & LF170F**

Thank you for purchasing our ProSeries Engine!

**All information in this publication is based on the latest product information available
at the time of approval for printing. We reserve the right to make changes at any time
without notice and without incurring any obligation. The copyright of this manual
belongs to EquipSource, LLC. No parts of this publication may be reproduced without
the written permission of EquipSource, LLC. This manual should be considered a
permanent part of the generator and should remain with it if is resold.**

**For Product Support and Service Please Scan the QR Code Below
or Visit Us at www.lifanpowerusa.com
or Call Toll Free 1-866-471-7464**

